

Gene Section

Review

EHMT2 (euchromatic histone-lysine N-methyltransferase 2)

Chandra-Prakash Chaturvedi, Marjorie Brand

The Sprott Center for Stem Cell Research, Regenerative Medicine Program, Ottawa Hospital Research Institute, Ottawa, ON K1H 8L6, Canada (CPC, MB), University of Ottawa, Department of Cellular and Molecular Medicine, University of Ottawa, ON K1H 8L6, Canada (MB)

Published in Atlas Database: July 2013

Online updated version : <http://AtlasGeneticsOncology.org/Genes/EHMT2ID51148ch6p21.html>
DOI: 10.4267/2042/52075

This work is licensed under a Creative Commons Attribution-Noncommercial-No Derivative Works 2.0 France Licence.
© 2014 Atlas of Genetics and Cytogenetics in Oncology and Haematology

Abstract: Review on EHMT2, with data on DNA/RNA, on the protein encoded and where the gene is implicated.

Identity

Other names: BAT8, C6orf30, G9A, GAT8, KMT1C, NG36

HGNC (Hugo): EHMT2

Location: 6p21.33

Local order: HSPA1A - HSPA1B - NEU1 - SLC44A4 - EHMT2 - C2 - ZBTB12.

DNA/RNA

Description

The human EHMT2/G9a Gene (NC_000006.11) is located on the minus strand and spans 17929 bps of genomic region (31847536 - 31865464). The long isoform of EHMT2/G9a comprises 28 exons,

whereas the short isoform consists of 27 exons and lacks the sequence corresponding to exon 10 of the long isoform.

Transcription

EHMT2/G9a gene has two differentially spliced transcript variants (Brown et al., 2001). G9a transcript variant I NG36/EHMT2 (accession number NM_006709.3) also called long isoform or isoform a, has 3982 bps open reading frame. G9a transcript variant II NG36/EHMT2-SP1 (accession number NM_025256.5) also called short Isoform or isoform b, has open reading frame of 3880 bps (Brown et al., 2001).

Pseudogene

There is no known pseudogene for EHMT2/G9a.

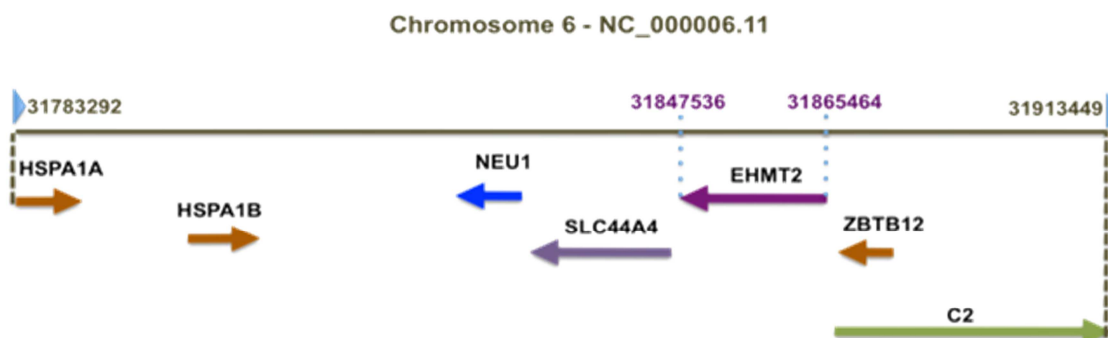

Genomic location of EHMT2/G9a gene along with adjustment genes on chromosome 6 (minus strand).

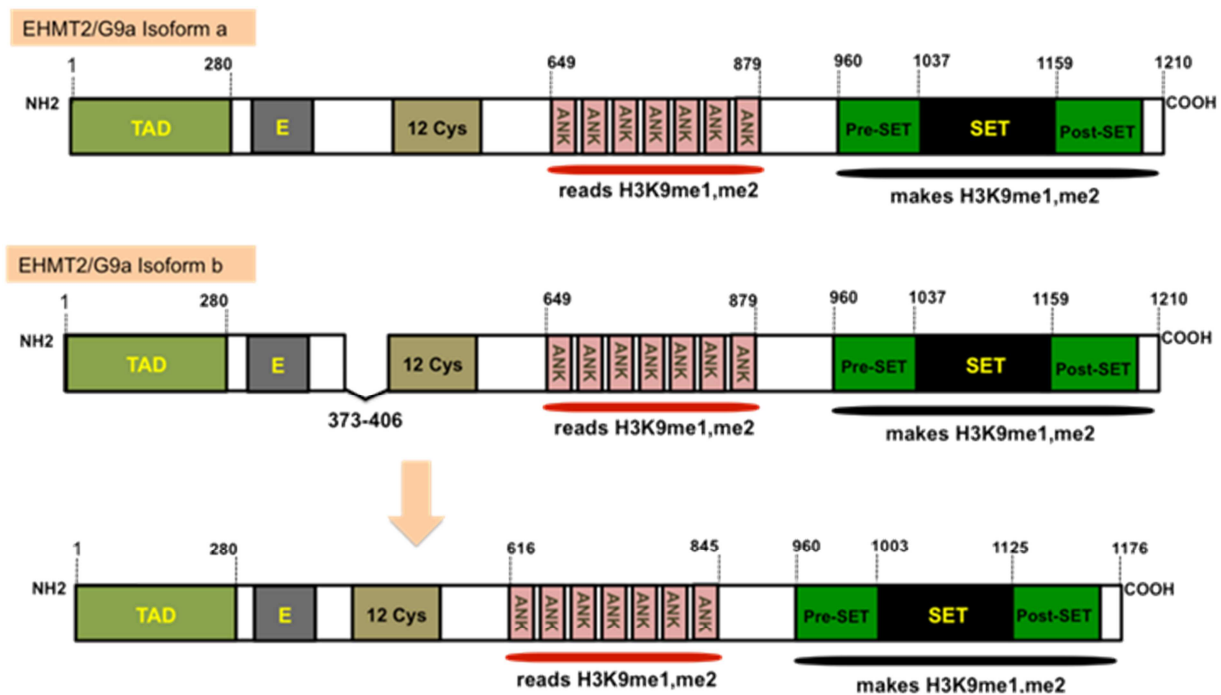

Schematic representation of the domain structure of EHMT2/G9a isoform a and isoform b. Isoform b is missing amino acid sequence 373-406 (34 aa) compared to the canonical isoform a (aa 1-1210). Isoform b is numbered according to isoform a, as well as separately. The positions of known domains within G9a are displayed. Transcription activation domain (TAD), E rich, glutamine-rich domain, NRSF-binding cysteine rich domain (12Cys) and ankyrin domain with seven ankyrin repeats and Set domain containing pre and post SET domains.

Transcriptionally, G9a can function both as a corepressor and/or a coactivator of gene expression, (Collins and Cheng, 2010; Yoichi and Tachibana, 2011; Shnakar et al., 2013; Lee et al., 2006; Chaturvedi et al., 2009; Purcell et al., 2011; Chaturvedi et al., 2012; Bittencourt et al., 2012). The corepressor function of the G9a is dependent on its enzymatic activity as well as on its interaction with other factors that are involved in gene repression (Tachibana et al., 2002; Yoichi and Tachibana, 2011; Chaturvedi et al., 2012; Shnakar et al., 2013). G9a gets targeted to specific genes by associating with various transcriptional repressors and corepressors such as, CDP/Cut, E2F6, Gfi1/zfp163, Blimp-1/PRDI-BF1, REST/NRSF, ZNF217 and PRISM/PRDM6 and several others (Tachibana et al., 2002; Ogawa et al., 2002; Gyory et al., 2004; Nashio and Walsh, 2004; Roopra et al., 2004; Daun et al., 2005; Davis et al., 2006; Nagano et al., 2008; Banck et al., 2009; Yoichi and Tachibana, 2011; Shnakar et al., 2013). The coactivator function of the G9a does not require its enzymatic activity but requires association with other transcriptional activators and/or coactivators factors including CARM1, p300, RNA polymerases or the Mediator complex (Lee et al., 2006; Chaturvedi et al., 2009; Purcell et al., 2011; Bittencourt et al., 2012; Chaturvedi et al., 2012).

Functionally, G9a has been shown to play important roles in regulating the expression of genes involved in various developmental and differentiation processes.

G9a is indispensable for early embryonic development (Tachibana et al., 2002; Yoichi and Tachibana, 2011). The G9a knockout embryonic stem cells (ESCs) show severe defects in differentiation, suggesting that G9a positively regulates ESCs differentiation (Tachibana et al., 2002; Feldman et al., 2006; Kubicek et al., 2007; Shi et al., 2008). Similarly, G9a is required for proper differentiation, survival and lineage commitment of adult or somatic stem cells i.e hematopoietic progenitor stem cells, retinal progenitor cells (Chen et al., 2012; Katoh et al., 2012). Genome wide studies have revealed the presence of G9a mediated large H3K9 dimethylation (H3K9me2) chromatin blocks (LOCKS) on large chromatin region in the genome (Wen et al., 2009; Chen et al., 2012). These G9a mediated LOCKS are necessary for proper differentiation as the loss of LOCKs inhibits or delays differentiation and lineage commitment of both embryonic and adult stem cells (Wen et al., 2009; Chen et al., 2012). In contrast to its positive regulatory role in maintaining differentiation, G9a has been shown to negatively regulate differentiation by repressing differentiation specific genes in myogenesis and adipogenesis (Shankar et al., 2013; Ling et al., 2012a; Ling et al., 2012b; Wang and Abete-Shen, 2011; Wang et al., 2013). Furthermore, G9a has been shown to regulate gene expression in multiple other biological processes including, genomic imprinting (Nagano et al., 2008; Wagschal et al., 2008), germ cells development (Tachibana et al., 2007), erythropoiesis (Chaturvedi et

al., 2009; Chaturvedi et al., 2012), T and B cell mediated immune response (Thomas et al., 2008; Lehnertz et al., 2010) and nuclear receptor mediated gene expression (Lee et al., 2006; Purcell et al., 2011; Bittencourt et al., 2012).

In the brain, G9a is required for proper expression of genes involved in lineage specific expression (Roopra et al., 2004, Schaefer et al., 2009), memory consolidation (Gupta et al., 2012), and cocaine induced neuronal responses and behavioural plasticity (Maze et al., 2010).

G9a has been also shown to plays critical role in cell proliferation (Yang et al., 2012), senescence (Takahashi et al., 2012), DNA replication (Esteve et al., 2006; Yu et al., 2012), and in the establishment of proviral gene silencing (Leung et al., 2011).

Homology

EHMT2/G9a homologues have been found in various species like chimpanzee (99.7 % homology), cow (98.1% homology), rat (95.97% homology), *C. elegans* (25 % homology) and mouse (95.5% homology).

Mutations

Germinal

No mutations have been reported so far.

Somatic

No mutations have been reported so far.

Implicated in

Various cancers

Note

EHMT2/G9a is overexpressed in various types of tumors, which include solid and haematological tumors (Cho et al., 2011). High-level expression of G9a in cancerous cells has been correlated with aggressiveness and poor prognosis in patients of lung, hepatocellular, ovarian, colon cancer and B cell chronic lymphocytic leukemia (Haung et al., 2010).

Functionally, G9a has been linked to multiple cellular functions associated with tumor progression including proliferation, adhesion, migration, invasion, and cancer stem cell maintenance.

Knockdown of G9a protein in cancer cells induces apoptosis suggesting that G9a plays a crucial role in cell cycle regulation of cancerous cells (Watanabe et al., 2008).

Use of G9a-specific inhibitors, had been shown to significantly suppress the growth of cancerous cells, indicating that G9a enzymatic activity plays an important role in cancer development and growth (Cho et al., 2011).

The following paragraphs summarize the discoveries on the functional role of G9a in various types of cancer development.

Lung cancer

Note

Lung cancer is a disease characterized by uncontrolled cell growth of lung tissue. G9a is highly expressed in aggressive lung cancer cells, and its elevated level has been correlated to poor prognosis with increase in cell migration, invasion and metastasis (Chen et al., 2010). G9a enhances the metastasis of lung cancer cells by repressing expression of the cell adhesion molecule Ep-CAM. High level of G9a in lung cancer cells promotes enrichment of DNA methylation and H3K9 dimethylation marks on Ep-CAM gene promoter region, leading to repression of this gene (Chen et al., 2010).

Depletion of the G9a protein in lung cancer cells reduces the levels of H3K9 dimethylation and decreases recruitment of the transcriptional cofactors HP1, DNMT1, and HDAC1 to the Ep-CAM promoter, leading to de-repression of Ep-CAM gene and inhibition of cell migration and invasion (Chen et al., 2010).

Breast cancer

Note

Human breast cancer is a heterogeneous disease with respect to molecular alterations, incidence, survival, and response to therapy. Claudin-low breast cancer (CLBC) is characterized by the expression of markers of epithelial-mesenchymal transition (EMT), which has been linked with CLBC metastasis (Dong et al., 2012). G9a promotes EMT expression by repressing E-cadherin expression in CLBC models. G9a associates with Snail and recruits HP1 and DNA methyltransferases to the E-cadherin gene promoter for repression (Dong et al., 2012).

Knockdown of G9a in CLBC models restores E-cadherin expression by suppressing H3K9me2 and DNA methylation, which results in inhibition of cell migration, invasion, suppression of tumor growth and metastasis (Dong et al., 2012).

Prostate cancer

Note

Prostate cancer is one of the most frequent cancers in men. G9a is coexpressed at high levels with Runx2, in metastatic prostate cancer cells and directly regulates the expression of several Runx2 target genes, which are important regulators of tumor growth, invasion and/or metastasis (Purcell et al., 2012).

Downregulation of G9a in prostate cancer cells represses several RUNX2 target genes including, MMP9, CSF2, SDF1, CST7 and enhances the expression of others, such as MMP13 and PIP (Purcell et al., 2012). A study by Kondo et al., (2008) demonstrates that downregulation of G9a in prostate cancer cells, disrupts centrosome and chromosome stability, leading to inhibition of cancer cell growth.

Another study by Yuan et al., (2012) demonstrates that treatment of pancreatic cancer cells with G9a inhibitor BRD4770 induces senescence and inhibits proliferation. Collectively, these studies reveal a potential oncogenic role of G9a in prostate cancer progression.

Gastric cancer

Note

G9a is involved in gastric cancer progression by inhibiting expression of the tumor suppressor gene RUNX3. In RUNX3 expressing gastric cell lines, hypoxia leads to upregulation of G9a, leading to the accumulation of H3K9me2 marks on RUNX3 promoter and repression of RUNX3 expression (Lee et al., 2009). Knocking down G9a in hypoxia-induced gastric cancer cells restores the expression of RUNX3 with suppression of gastric cancer progression (Lee et al., 2009).

Bladder carcinomas

Note

G9a expression is upregulated in human bladder carcinomas compared to non-neoplastic bladder tissues (Cho et al., 2011).

Enhanced expression of G9a promotes the proliferation of bladder carcinomas cells by negatively regulating the tumor suppressor gene SIAH1 (Cho et al., 2011).

G9a suppresses transcription of the SIAH1 gene by binding to its promoter followed by methylation of lysine 9 of histone H3.

Downregulation of G9a activity by knock down or through the use of a G9a specific inhibitor, BIX-01294, significantly suppresses the growth of cancer cells by de-repressing the SIAH1 gene (Cho et al., 2011).

Neuroendocrine tumors

Note

Neuroendocrine tumors (NETs) are neoplasms that arise from cells of the endocrine and nervous systems. A study by Kim et al., (2013) has revealed altered expression of Wnt/ β -catenin signaling components in neuroendocrine tumors.

G9a contributes to the pathogenesis and growth of NETs by upregulating the expression of β -catenin. High level expression of G9a in neuroendocrine tumors downregulates the expression of specific β -catenin inhibitory genes including DKK-1, DKK-2, and WIF-1, leading to overexpression of β -catenin, which in turn leads to increased cell proliferation and tumor growth (Kim et al., 2013).

Use of the G9a inhibitor UNC0638 derepresses β -catenin inhibitory genes and suppresses Wnt/ β -catenin induced cell proliferation, colony formation and tumor growth, demonstrating the oncogenic potential of G9a in NETs progression (Kim et al., 2013).

Haematological malignancies

Note

G9a is over expressed in haematological malignancies including AML and CML (Haung et al., 2010; Cho et al., 2011).

The oncoprotein EVI-1 (ecotropic viral integration site-1) is aberrantly expressed in myeloid leukemias and has been linked to a poor patient survival rate. A study by Goyama et al., (2010) demonstrates that G9a interacts EVI-1 and contributes to EVI-1-mediated leukemogenesis.

Depletion of G9a protein in EVI-1-expressing progenitors significantly reduces their colony-forming activity, indicating a possible role of G9a in generating leukemia-initiating cells by Evi-1 (Goyama et al., 2010).

JAK2 (Janus kinase 2) mediated phosphorylation plays a critical role during normal hematopoiesis and leukemogenesis.

JAK2 induces leukemogenesis by activating the lmo2 leukemogenic gene through phosphorylation of histone H3Y41 and exclusion of HP1 α from chromatin (Dawson et al., 2009).

A recent study by Son et al., (2012) demonstrated that G9a negatively regulates the expression of JAK2 and favors ATRA-mediated leukemia cell differentiation. G9a mediated repression of JAK2, results in the downregulation of H3Y41 phosphorylation on the leukemogenic oncogene lmo2 promoter, indicating a role for G9a in JAK2-H3Y41P-HP1 α transcriptional signaling during leukemogenesis (Son et al., 2012).

Breakpoints

Note

No variables are reported for EHMT2/G9a gene so far.

To be noted

Note

In summary, dysregulation of EHMT2/G9a is emerging as an important player in the pathobiology of various forms of cancer suggesting that G9a could serve as a promising therapeutic target for future treatments notably through the use of specific chemical inhibitors. For example, BIX-01294; a specific inhibitor of G9a methyltransferase activity has been shown to effectively suppress the growth of cancer cells (Cho et al., 2011).

Another G9a inhibitor, BRD4770 induces senescence and inhibits proliferation of cancer cells (Yuan et al., 2012). Finally, a third G9a inhibitor UNC0638 showed similar results as BIX-01294 and BRD4770 and inhibits cell proliferation, colony formation and tumor growth (Kim et al., 2013).

It will be interesting to test the effectiveness of these inhibitors *in vivo*. Further studies are required for better understanding of the molecular mechanism of G9a mediated positive and negative gene regulatory role in cancer development and for developing efficient therapy.

References

- Spies T, Bresnahan M, Strominger JL. Human major histocompatibility complex contains a minimum of 19 genes between the complement cluster and HLA-B. *Proc Natl Acad Sci U S A*. 1989 Nov;86(22):8955-8
- Milner CM, Campbell RD. The G9a gene in the human major histocompatibility complex encodes a novel protein containing ankyrin-like repeats. *Biochem J*. 1993 Mar 15;290 (Pt 3):811-8
- Sedgwick SG, Smerdon SJ. The ankyrin repeat: a diversity of interactions on a common structural framework. *Trends Biochem Sci*. 1999 Aug;24(8):311-6
- Brown SE, Campbell RD, Sanderson CM. Novel NG36/G9a gene products encoded within the human and mouse MHC class III regions. *Mamm Genome*. 2001 Dec;12(12):916-24
- Tachibana M, Sugimoto K, Fukushima T, Shinkai Y. Set domain-containing protein, G9a, is a novel lysine-preferring mammalian histone methyltransferase with hyperactivity and specific selectivity to lysines 9 and 27 of histone H3. *J Biol Chem*. 2001 Jul 6;276(27):25309-17
- Ogawa H, Ishiguro K, Gaubatz S, Livingston DM, Nakatani Y. A complex with chromatin modifiers that occupies E2F- and Myc-responsive genes in G0 cells. *Science*. 2002 May 10;296(5570):1132-6
- Tachibana M, Sugimoto K, Nozaki M, Ueda J, Ohta T, Ohki M, Fukuda M, Takeda N, Niida H, Kato H, Shinkai Y. G9a histone methyltransferase plays a dominant role in euchromatic histone H3 lysine 9 methylation and is essential for early embryogenesis. *Genes Dev*. 2002 Jul 15;16(14):1779-91
- Gyory I, Wu J, Fejér G, Seto E, Wright KL. PRDI-BF1 recruits the histone H3 methyltransferase G9a in transcriptional silencing. *Nat Immunol*. 2004 Mar;5(3):299-308
- Nishio H, Walsh MJ. CCAAT displacement protein/cut homolog recruits G9a histone lysine methyltransferase to repress transcription. *Proc Natl Acad Sci U S A*. 2004 Aug 3;101(31):11257-62
- Roopra A, Qazi R, Schoenike B, Daley TJ, Morrison JF. Localized domains of G9a-mediated histone methylation are required for silencing of neuronal genes. *Mol Cell*. 2004 Jun 18;14(6):727-38
- Dillon SC, Zhang X, Trievel RC, Cheng X. The SET-domain protein superfamily: protein lysine methyltransferases. *Genome Biol*. 2005;6(8):227
- Duan Z, Zarebski A, Montoya-Durango D, Grimes HL, Horwitz M. Gfi1 coordinates epigenetic repression of p21Cip/WAF1 by recruitment of histone lysine methyltransferase G9a and histone deacetylase 1. *Mol Cell Biol*. 2005 Dec;25(23):10338-51
- Tachibana M, Ueda J, Fukuda M, Takeda N, Ohta T, Iwanari H, Sakihama T, Kodama T, Hamakubo T, Shinkai Y. Histone methyltransferases G9a and GLP form heteromeric complexes and are both crucial for methylation of euchromatin at H3-K9. *Genes Dev*. 2005 Apr 1;19(7):815-26
- Stewart MD, Li J, Wong J. Relationship between histone H3 lysine 9 methylation, transcription repression, and heterochromatin protein 1 recruitment. *Mol Cell Biol*. 2005 Apr;25(7):2525-38
- Davis CA, Haberland M, Arnold MA, Sutherland LB, McDonald OG, Richardson JA, Childs G, Harris S, Owens GK, Olson EN. PRISM/PRDM6, a transcriptional repressor that promotes the proliferative gene program in smooth muscle cells. *Mol Cell Biol*. 2006 Apr;26(7):2626-36
- Estève PO, Chin HG, Smallwood A, Feehery GR, Gangisetty O, Karpf AR, Carey MF, Pradhan S. Direct interaction between DNMT1 and G9a coordinates DNA and histone methylation during replication. *Genes Dev*. 2006 Nov 15;20(22):3089-103
- Feldman N, Gerson A, Fang J, Li E, Zhang Y, Shinkai Y, Cedar H, Bergman Y. G9a-mediated irreversible epigenetic inactivation of Oct-3/4 during early embryogenesis. *Nat Cell Biol*. 2006 Feb;8(2):188-94
- Lee DY, Northrop JP, Kuo MH, Stallcup MR. Histone H3 lysine 9 methyltransferase G9a is a transcriptional coactivator for nuclear receptors. *J Biol Chem*. 2006 Mar 31;281(13):8476-85
- Ueda J, Tachibana M, Ikura T, Shinkai Y. Zinc finger protein Wiz links G9a/GLP histone methyltransferases to the co-repressor molecule CtBP. *J Biol Chem*. 2006 Jul 21;281(29):20120-8
- Chin HG, Estève PO, Pradhan M, Benner J, Patnaik D, Carey MF, Pradhan S. Automethylation of G9a and its implication in wider substrate specificity and HP1 binding. *Nucleic Acids Res*. 2007;35(21):7313-23
- Kubicek S, O'Sullivan RJ, August EM, Hickey ER, Zhang Q, Teodoro ML, Rea S, Mechtler K, Kowalski JA, Honom CA, Kelly TA, Jenuwein T. Reversal of H3K9me2 by a small-molecule inhibitor for the G9a histone methyltransferase. *Mol Cell*. 2007 Feb 9;25(3):473-81
- Tachibana M, Nozaki M, Takeda N, Shinkai Y. Functional dynamics of H3K9 methylation during meiotic prophase progression. *EMBO J*. 2007 Jul 25;26(14):3346-59
- Collins RE, Northrop JP, Horton JR, Lee DY, Zhang X, Stallcup MR, Cheng X. The ankyrin repeats of G9a and GLP histone methyltransferases are mono- and dimethyllysine binding modules. *Nat Struct Mol Biol*. 2008 Mar;15(3):245-50
- Epsztejn-Litman S, Feldman N, Abu-Remaileh M, Shufaro Y, Gerson A, Ueda J, Deplus R, Fuks F, Shinkai Y, Cedar H, Bergman Y. De novo DNA methylation promoted by G9a prevents reprogramming of embryonically silenced genes. *Nat Struct Mol Biol*. 2008 Nov;15(11):1176-83
- Dong KB, Maksakova IA, Mohn F, Leung D, Appanah R, Lee S, Yang HW, Lam LL, Mager DL, Schübeler D, Tachibana M, Shinkai Y, Loricz MC. DNA methylation in ES cells requires the lysine methyltransferase G9a but not its catalytic activity. *EMBO J*. 2008 Oct 22;27(20):2691-701
- Kondo Y, Shen L, Ahmed S, Bumber Y, Sekido Y, Haddad BR, Issa JP. Downregulation of histone H3 lysine 9 methyltransferase G9a induces centrosome disruption and chromosome instability in cancer cells. *PLoS One*. 2008 Apr 30;3(4):e2037
- Nagano T, Mitchell JA, Sanz LA, Pauler FM, Ferguson-Smith AC, Feil R, Fraser P. The Air noncoding RNA epigenetically silences transcription by targeting G9a to chromatin. *Science*. 2008 Dec 12;322(5908):1717-20
- Rathert P, Dhayalan A, Murakami M, Zhang X, Tamas R, Jurkowska R, Komatsu Y, Shinkai Y, Cheng X, Jeltsch A. Protein lysine methyltransferase G9a acts on non-histone targets. *Nat Chem Biol*. 2008 Jun;4(6):344-6
- Shi Y, Desponts C, Do JT, Hahm HS, Schöler HR, Ding S. Induction of pluripotent stem cells from mouse embryonic

- fibroblasts by Oct4 and Klf4 with small-molecule compounds. *Cell Stem Cell*. 2008 Nov 6;3(5):568-74
- Tachibana M, Matsumura Y, Fukuda M, Kimura H, Shinkai Y. G9a/GLP complexes independently mediate H3K9 and DNA methylation to silence transcription. *EMBO J*. 2008 Oct 22;27(20):2681-90
- Thomas LR, Miyashita H, Cobb RM, Pierce S, Tachibana M, Hobeika E, Reth M, Shinkai Y, Oltz EM. Functional analysis of histone methyltransferase g9a in B and T lymphocytes. *J Immunol*. 2008 Jul 1;181(1):485-93
- Wagschal A, Sutherland HG, Woodfine K, Henckel A, Chebli K, Schulz R, Oakey RJ, Bickmore WA, Feil R. G9a histone methyltransferase contributes to imprinting in the mouse placenta. *Mol Cell Biol*. 2008 Feb;28(3):1104-13
- Watanabe H, Soejima K, Yasuda H, Kawada I, Nakachi I, Yoda S, Naoki K, Ishizaka A. Dereglulation of histone lysine methyltransferases contributes to oncogenic transformation of human bronchoepithelial cells. *Cancer Cell Int*. 2008 Nov 3;8:15
- Banck MS, Li S, Nishio H, Wang C, Beutler AS, Walsh MJ. The ZNF217 oncogene is a candidate organizer of repressive histone modifiers. *Epigenetics*. 2009 Feb 16;4(2):100-6
- Chaturvedi CP, Hosey AM, Palii C, Perez-Iratxeta C, Nakatani Y, Ranish JA, Dilworth FJ, Brand M. Dual role for the methyltransferase G9a in the maintenance of beta-globin gene transcription in adult erythroid cells. *Proc Natl Acad Sci U S A*. 2009 Oct 27;106(43):18303-8
- Dawson MA, Bannister AJ, Göttgens B, Foster SD, Bartke T, Green AR, Kouzarides T. JAK2 phosphorylates histone H3Y41 and excludes HP1alpha from chromatin. *Nature*. 2009 Oct 8;461(7265):819-22
- Lee SH, Kim J, Kim WH, Lee YM. Hypoxic silencing of tumor suppressor RUNX3 by histone modification in gastric cancer cells. *Oncogene*. 2009 Jan 15;28(2):184-94
- Schaefer A, Sampath SC, Intrator A, Min A, Gertler TS, Surmeier DJ, Tarakhovskiy A, Greengard P. Control of cognition and adaptive behavior by the GLP/G9a epigenetic suppressor complex. *Neuron*. 2009 Dec 10;64(5):678-91
- Trojer P, Zhang J, Yonezawa M, Schmidt A, Zheng H, Jenuwein T, Reinberg D. Dynamic Histone H1 Isotype 4 Methylation and Demethylation by Histone Lysine Methyltransferase G9a/KMT1C and the Jumonji Domain-containing JMJD2/KDM4 Proteins. *J Biol Chem*. 2009 Mar 27;284(13):8395-405
- Wen B, Wu H, Shinkai Y, Irizarry RA, Feinberg AP. Large histone H3 lysine 9 dimethylated chromatin blocks distinguish differentiated from embryonic stem cells. *Nat Genet*. 2009 Feb;41(2):246-50
- Chen MW, Hua KT, Kao HJ, Chi CC, Wei LH, Johansson G, Shiah SG, Chen PS, Jeng YM, Cheng TY, Lai TC, Chang JS, Jan YH, Chien MH, Yang CJ, Huang MS, Hsiao M, Kuo ML. H3K9 histone methyltransferase G9a promotes lung cancer invasion and metastasis by silencing the cell adhesion molecule Ep-CAM. *Cancer Res*. 2010 Oct 15;70(20):7830-40
- Collins R, Cheng X. A case study in cross-talk: the histone lysine methyltransferases G9a and GLP. *Nucleic Acids Res*. 2010 Jun;38(11):3503-11
- Goyama S, Nitta E, Yoshino T, Kako S, Watanabe-Okochi N, Shimabe M, Imai Y, Takahashi K, Kurokawa M. EVI-1 interacts with histone methyltransferases SUV39H1 and G9a for transcriptional repression and bone marrow immortalization. *Leukemia*. 2010 Jan;24(1):81-8
- Huang J, Dorsey J, Chuikov S, Pérez-Burgos L, Zhang X, Jenuwein T, Reinberg D, Berger SL. G9a and Glp methylate lysine 373 in the tumor suppressor p53. *J Biol Chem*. 2010 Mar 26;285(13):9636-41
- Lehnertz B, Northrop JP, Antignano F, Burrows K, Hadidi S, Mullaly SC, Rossi FM, Zaph C. Activating and inhibitory functions for the histone lysine methyltransferase G9a in T helper cell differentiation and function. *J Exp Med*. 2010 May 10;207(5):915-22
- Maze I, Covington HE 3rd, Dietz DM, LaPlant Q, Renthal W, Russo SJ, Mechanic M, Mouzon E, Neve RL, Haggarty SJ, Ren Y, Sampath SC, Hurd YL, Greengard P, Tarakhovskiy A, Schaefer A, Nestler EJ. Essential role of the histone methyltransferase G9a in cocaine-induced plasticity. *Science*. 2010 Jan 8;327(5962):213-6
- Weiss T, Hergeth S, Zeissler U, Izzo A, Tropberger P, Zee BM, Dunder M, Garcia BA, Daujat S, Schneider R. Histone H1 variant-specific lysine methylation by G9a/KMT1C and Glp1/KMT1D. *Epigenetics Chromatin*. 2010 Mar 24;3(1):7
- Chang Y, Sun L, Kokura K, Horton JR, Fukuda M, Espejo A, Izumi V, Koomen JM, Bedford MT, Zhang X, Shinkai Y, Fang J, Cheng X. MPP8 mediates the interactions between DNA methyltransferase Dnmt3a and H3K9 methyltransferase GLP/G9a. *Nat Commun*. 2011 Nov 15;2:533
- Cho HS, Kelly JD, Hayami S, Toyokawa G, Takawa M, Yoshimatsu M, Tsunoda T, Field HI, Neal DE, Ponder BA, Nakamura Y, Hamamoto R. Enhanced expression of EHMT2 is involved in the proliferation of cancer cells through negative regulation of SIAH1. *Neoplasia*. 2011 Aug;13(8):676-84
- Leung DC, Dong KB, Maksakova IA, Goyal P, Appanah R, Lee S, Tachibana M, Shinkai Y, Lehnertz B, Mager DL, Rossi F, Lorincz MC. Lysine methyltransferase G9a is required for de novo DNA methylation and the establishment, but not the maintenance, of proviral silencing. *Proc Natl Acad Sci U S A*. 2011 Apr 5;108(14):5718-23
- Purcell DJ, Jeong KW, Bittencourt D, Gerke DS, Stallcup MR. A distinct mechanism for coactivator versus corepressor function by histone methyltransferase G9a in transcriptional regulation. *J Biol Chem*. 2011 Dec 9;286(49):41963-71
- Shinkai Y, Tachibana M. H3K9 methyltransferase G9a and the related molecule GLP. *Genes Dev*. 2011 Apr 15;25(8):781-8
- Wu H, Chen X, Xiong J, Li Y, Li H, Ding X, Liu S, Chen S, Gao S, Zhu B. Histone methyltransferase G9a contributes to H3K27 methylation in vivo. *Cell Res*. 2011 Feb;21(2):365-7
- Bittencourt D, Wu DY, Jeong KW, Gerke DS, Herviou L, Ianculescu I, Chodankar R, Siegmund KD, Stallcup MR. G9a functions as a molecular scaffold for assembly of transcriptional coactivators on a subset of glucocorticoid receptor target genes. *Proc Natl Acad Sci U S A*. 2012 Nov 27;109(48):19673-8
- Chaturvedi CP, Somasundaram B, Singh K, Carpenedo RL, Stanford WL, Dilworth FJ, Brand M. Maintenance of gene silencing by the coordinate action of the H3K9 methyltransferase G9a/KMT1C and the H3K4 demethylase Jarid1a/KDM5A. *Proc Natl Acad Sci U S A*. 2012 Nov 13;109(46):18845-50
- Chen X, Skutt-Kakaria K, Davison J, Ou YL, Choi E, Malik P, Loeb K, Wood B, Georges G, Torok-Storb B, Paddison PJ. G9a/GLP-dependent histone H3K9me2 patterning during human hematopoietic stem cell lineage commitment. *Genes Dev*. 2012 Nov 15;26(22):2499-511
- Dong C, Wu Y, Yao J, Wang Y, Yu Y, Rychahou PG, Evers BM, Zhou BP. G9a interacts with Snail and is critical for Snail-mediated E-cadherin repression in human breast cancer. *J Clin Invest*. 2012 Apr 2;122(4):1469-86

- Gupta-Agarwal S, Franklin AV, Deramus T, Wheelock M, Davis RL, McMahon LL, Lubin FD. G9a/GLP histone lysine dimethyltransferase complex activity in the hippocampus and the entorhinal cortex is required for gene activation and silencing during memory consolidation. *J Neurosci*. 2012 Apr 18;32(16):5440-53
- Kato H, Yamazaki R, Onishi A, Sanuki R, Furukawa T. G9a histone methyltransferase activity in retinal progenitors is essential for proper differentiation and survival of mouse retinal cells. *J Neurosci*. 2012 Dec 5;32(49):17658-70
- Ling BM, Bharathy N, Chung TK, Kok WK, Li S, Tan YH, Rao VK, Gopinadhan S, Sartorelli V, Walsh MJ, Taneja R. Lysine methyltransferase G9a methylates the transcription factor MyoD and regulates skeletal muscle differentiation. *Proc Natl Acad Sci U S A*. 2012 Jan 17;109(3):841-6
- Ling BM, Gopinadhan S, Kok WK, Shankar SR, Gopal P, Bharathy N, Wang Y, Taneja R. G9a mediates Sharp-1-dependent inhibition of skeletal muscle differentiation. *Mol Biol Cell*. 2012 Dec;23(24):4778-85
- Purcell DJ, Khalid O, Ou CY, Little GH, Frenkel B, Baniwal SK, Stallcup MR. Recruitment of coregulator G9a by Runx2 for selective enhancement or suppression of transcription. *J Cell Biochem*. 2012 Jul;113(7):2406-14
- Son HJ, Kim JY, Hahn Y, Seo SB. Negative regulation of JAK2 by H3K9 methyltransferase G9a in leukemia. *Mol Cell Biol*. 2012 Sep;32(18):3681-94
- Takahashi A, Imai Y, Yamakoshi K, Kuninaka S, Ohtani N, Yoshimoto S, Hori S, Tachibana M, Anderton E, Takeuchi T, Shinkai Y, Peters G, Saya H, Hara E. DNA damage signaling triggers degradation of histone methyltransferases through APC/C(Cdh1) in senescent cells. *Mol Cell*. 2012 Jan 13;45(1):123-31
- Wang J, Abate-Shen C. The MSX1 homeoprotein recruits G9a methyltransferase to repressed target genes in myoblast cells. *PLoS One*. 2012;7(5):e37647
- Yamamizu K, Fujihara M, Tachibana M, Katayama S, Takahashi A, Hara E, Imai H, Shinkai Y, Yamashita JK. Protein kinase A determines timing of early differentiation through epigenetic regulation with G9a. *Cell Stem Cell*. 2012 Jun 14;10(6):759-70
- Yang Q, Lu Z, Singh D, Raj JU. BIX-01294 treatment blocks cell proliferation, migration and contractility in ovine foetal pulmonary arterial smooth muscle cells. *Cell Prolif*. 2012 Aug;45(4):335-44
- Yu Y, Song C, Zhang Q, DiMaggio PA, Garcia BA, York A, Carey MF, Grunstein M. Histone H3 lysine 56 methylation regulates DNA replication through its interaction with PCNA. *Mol Cell*. 2012 Apr 13;46(1):7-17
- Yuan Y, Wang Q, Paulk J, Kubicek S, Kemp MM, Adams DJ, Shamji AF, Wagner BK, Schreiber SL. A small-molecule probe of the histone methyltransferase G9a induces cellular senescence in pancreatic adenocarcinoma. *ACS Chem Biol*. 2012 Jul 20;7(7):1152-7
- Kim JT, Li J, Jang ER, Gulhati P, Rychahou PG, Napier DL, Wang C, Weiss HL, Lee EY, Anthony L, Townsend CM Jr, Liu C, Evers BM. Deregulation of Wnt/ β -catenin signaling through genetic or epigenetic alterations in human neuroendocrine tumors. *Carcinogenesis*. 2013 May;34(5):953-61
- Nair SS, Li DQ, Kumar R. A core chromatin remodeling factor instructs global chromatin signaling through multivalent reading of nucleosome codes. *Mol Cell*. 2013 Feb 21;49(4):704-18
- Shankar SR, Bahirvani AG, Rao VK, Bharathy N, Ow JR, Taneja R. G9a, a multipotent regulator of gene expression. *Epigenetics*. 2013 Jan;8(1):16-22
- Wang L, Xu S, Lee JE, Baldrige A, Grullon S, Peng W, Ge K. Histone H3K9 methyltransferase G9a represses PPAR γ expression and adipogenesis. *EMBO J*. 2013 Jan 9;32(1):45-59

This article should be referenced as such:

Chaturvedi CP, Brand M. EHMT2 (euchromatic histone-lysine N-methyltransferase 2). *Atlas Genet Cytogenet Oncol Haematol*. 2014; 18(1):38-45.
